

User Manual for



PHAB-S TWO CHANNEL TUBE PREAMP & STEREO SHUFFLER

This manual is also available as a pdf download, Go to: www.phaedrus-audio.com

THE PRE-AMP



Chapter 1 - Background

The new PHÆDRUS AUDIO PHAB-S is a 2RU, mains-powered unit. It is a recreation of two preamplifiers from the famous 1960s console used by The Beatles. Also included is the stereo shuffler which was an integral part of these *Stereosonic* consoles.

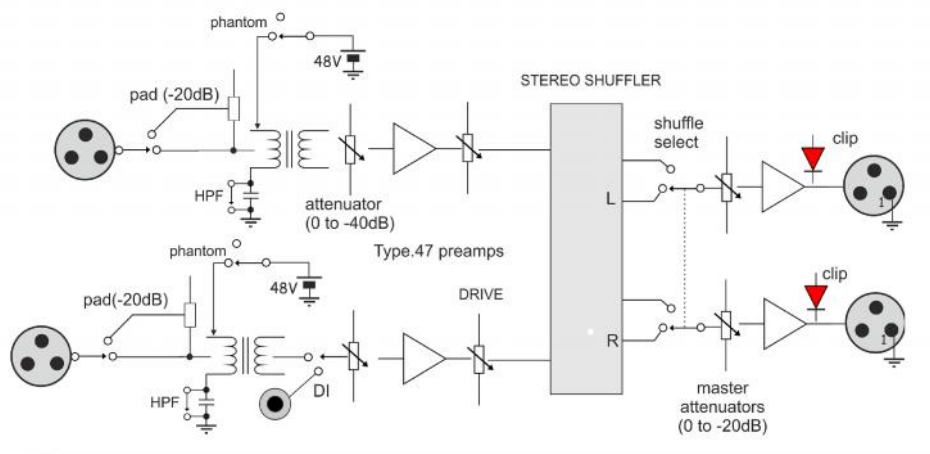

Chapter 2 - Warranty and Service

Please refer to for the latest information and advice about warranty and service at:
http://www.phaedrus-audio.com/phaedrus_t&cs.htm

Chapter 3 - Safety

General

Before using any piece of equipment manufactured by Phædrus Audio, be sure carefully to read the applicable items of these operating instructions and the safety suggestions. Keep them for future reference. Follow the warnings indicated on the unit, as well as in the operating instructions.



User Access & Servicing

Phædrus Audio equipment employs thermionic valve (vacuum-tube) technology and employs hazardous voltages for the high-tension supplies. THE USER SHOULD NOT ATTEMPT TO SERVICE THE UNIT. ALL SERVICING SHOULD BE REFERRED TO QUALIFIED SERVICE PERSONNEL OR FACTORY ONLY.

Phædrus Audio products should NEVER be connected to the external power supply or in any other way energised when the case is opened and/or the circuit board is accessible. Always replace mains fuse with a similar type (3 Amp).

General Safety Instructions

- Do not operate Phædrus Audio equipment near any source of water or in excessively moist environments.
- Keep your Phædrus Audio equipment away from babies, children and pets.
- Do not let objects do not fall, or liquids be spilled, into the enclosure.
- Situate the Phædrus Audio equipment away from heat sources or other equipment that produce heat.
- Ensure Phædrus Audio equipment has adequate ventilation. Improper ventilation will cause overheating, and can damage the equipment.
- When cleaning Phædrus Audio equipment, remove all connections to the unit; including power and gently wipe with a clean lint-free cloth; if necessary, gently moistened with lukewarm or distilled water. Use a dry lint-free cloth to remove any remaining moisture. NEVER use aerosol sprays, solvents, or abrasives on Phædrus Audio equipment.
- Phædrus Audio equipment should be serviced by qualified service personnel or returned to Phædrus Audio Ltd. when: an object (or objects) have fallen into the enclosure; or liquid has fallen into, or been spilled into the unit; or the unit has been exposed to rain or high humidity; or the unit does not operate normally or exhibits a marked change in performance; or the unit has been dropped, or the enclosure has been damaged.

Chapter 4 - Instructions for use

Phædrus Audio's products employ valves (vacuum tubes) in the audio path. Valves (vacuum tubes) and their associated circuitry need time to reach an electronic equilibrium before they will operate at optimal specifications. Please therefore allow these products to warm up for, at least, five minutes before using them in your signal chain. To prolong the life of your valves (tubes), it is recommended that you turn off these units when not in use.

Application and connections

The signal processing architecture of the PHAB-S is best understood by studying the block diagram as illustrated below.

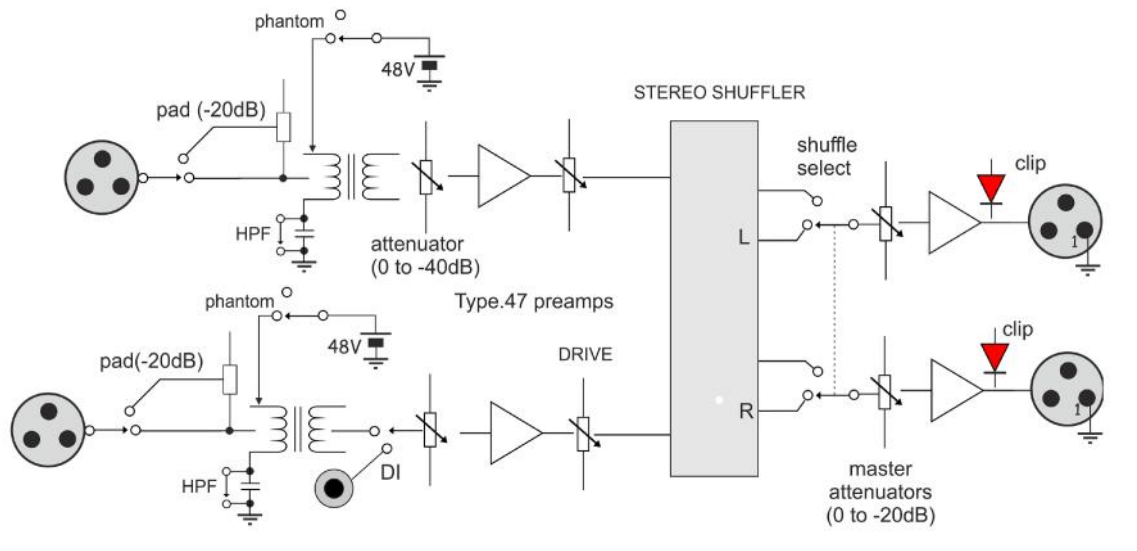

Architecture of the PHAB-S

Connecting up

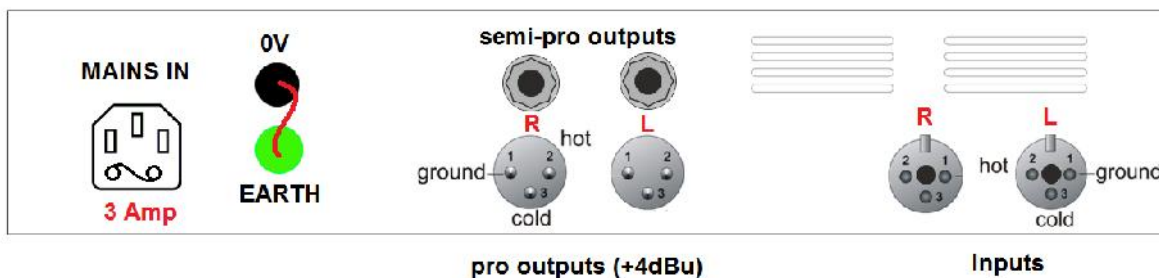

Rear panel view (for levels and impedances see Specification)

- Mains: Three core with earth on IEC connector.
 - For operation with a studio technical-earth, circuit 0V may be disconnected from mains earth by removing the wire link between the two binding posts on the rear chassis. The black terminal may then be connected to technical earth. The chassis is always connected to earth via the mains cord. The green terminal is hard-wired to the mains earth pin as illustrated below.

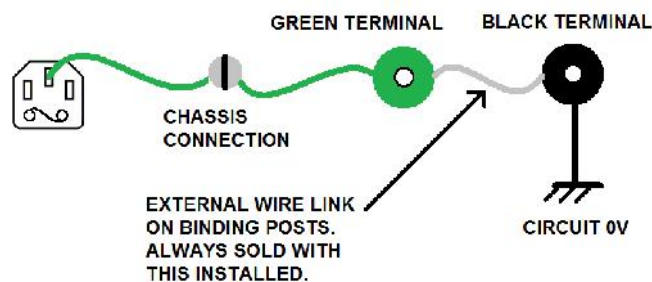



- **Never disconnect the mains earth from this equipment.**

- Inputs: accept balanced or unbalanced signals on XLRs or ¼ inch jacks (concentric connectors.)
- Outputs: +4dBu nominal fully balanced signals on XLR and balanced/unbalanced signals on ¼ inch jacks at -2dBu nominal. Outputs may be used concurrently with no interaction between pro and semi-pro outputs.

Input stage controls



The input stage controls consist of: the DI switch (right/ side channel only); the input attenuation controls (both channels); the phantom power switches; the DRIVE rotary switches; and the pad toggle switches.

The DI switch routes the signal on the front-panel jack to the preamplifiers. This control is only present on the right/side channel.

The input attenuation controls are precision, stepped attenuators maximum attenuation (at anti-clockwise end-stop) is 40dB.

The phantom power switches route 48V to the microphone inputs. **Please observe the usual precautions when selecting phantom power.**

DRIVE control

The standard configuration of the Type 47 amplifier module when used as a microphone preamp' was with 40dB gain and with no HPF engaged. The ability to change the gain, or to select the HPF in the original Type 47 amplifier was the duty of technical staff. Indeed, selection of the HPF involved powering down the console, waiting one minute whilst the killer HT voltage subsided, withdrawing the amplifier module and removing an internal link. And then refitting it all again. Hardly a user control then!

HPF

Nevertheless, when recording with a cardioid, or figure-of-eight microphone close to the talent, it is helpful to be able to attenuate the excess of low frequency information caused by

the proximity-effect. Thus, the first position on the DRIVE control permits simple selection of the HPF into the circuit: a luxury not easily afforded to the engineers working with The Beatles!

GAIN and +

The ability to select the higher gain regime of +46dB was included in the design of the Type 47 amplifier because the standard module played various duties in the console and, in some instances, this meant driving lower loads or making up for more loss in the mixing electronics.

Thus, when the Type 47 amplifier was operating at 46dB, it was not to give more gain in the sense we understand today, it was to work the amplifier harder to overcome more loss or to drive a lower load. This is the essence of the DRIVE control in the PHAB-S. In positions 3 and 4 of the DRIVE control, more gain is liberated from the amplifier, but the amplifier is also double, and then triple, terminated.

Thus, the DRIVE control needs to be used in conjunction with the input attenuation control.

When GAIN is selected, you will notice a small loss in volume caused by the extra load, this needs to be overcome by advancing the INPUT ATTEN' control. You will notice a "hardening" of the tone when operating the preamp in this way. The final position, exaggerates this effect. Still more gain is required to overcome the extra load and you will notice that the tube amplifier really starts to "show the strain".

Even more distorted effects may be obtained by reducing the master fader and driving the preamplifier even harder when GAIN/+ are selected.

Pad switch

The Pad switch introduces 20dB attenuation on the primary side of the input transformer.

Stereo Shuffling

(For information and history on Stereo Shuffling go here: http://www.phaedrus-audio.com/intro_to_shufflers.htm)

The PHAB-S incorporates the *Stereosonic* shuffler invented to correct for various shortcomings in conventional two-channel stereo. It is simply selected by switching the STEREO SHUFFLER control downwards.

As with the SHUFFLER in the original 1960s mixer, the correction circuit is entirely passive and therefore has some static *insertion loss*. That's to say that the signal level drops by about 2dB with the SHUFFLER in circuit. Compensate for this loss by advancing the master faders by one click when the SHUFFLER switch is operated.

Note that stereo shuffling is not appropriate when the preamplifier is being used as a two channel device, for example for a microphone and a guitar.

Master faders

The master faders are equivalent to the channel faders on a mixer. The inclusion of these controls allows you to, for example, to reduce the signal level at the master fader point, so that you can drive the channel harder.

Signal levels should be set using the blue-red overload indicator controls. The default setting for these controls is 12-o'clock.

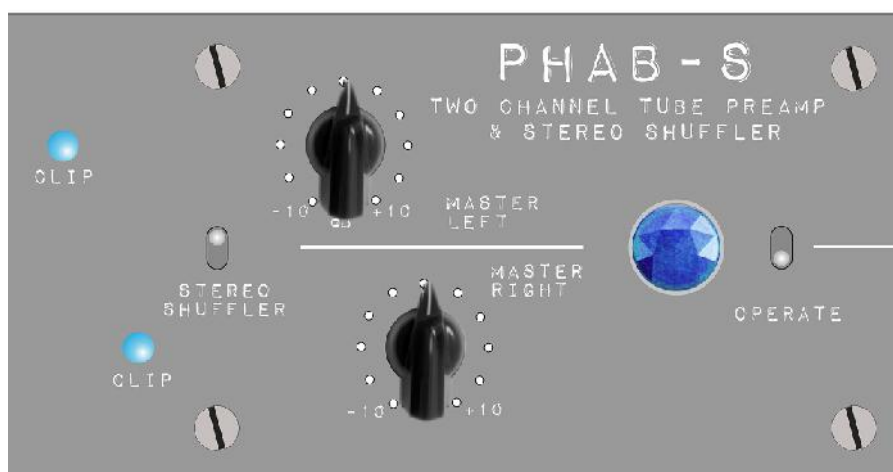

Operating levels & overload indicator

To prevent inadvertent clipping, the PHAB-S contains a clip detect circuit which turns the, normally blue, LEDs red when the audio level is 3dB below peak. This indicator should only be allowed to flash red occasionally in operation. The PHAB-S operates at the standard recording industry level of +4dBu = 0VU.

Chapter 6 - Circuit description

The Phædrus Audio PHAB-S microphone preamplifier incorporates the front-end of two channels of the famous *Stereosonic* consoles, in which the modular-amplifier is combined with a rotary attenuator, switchable pad, high-pass filter and gain-switching circuitry.

The amplifier block is known as a Type.47 and the circuit of this device is illustrated below.

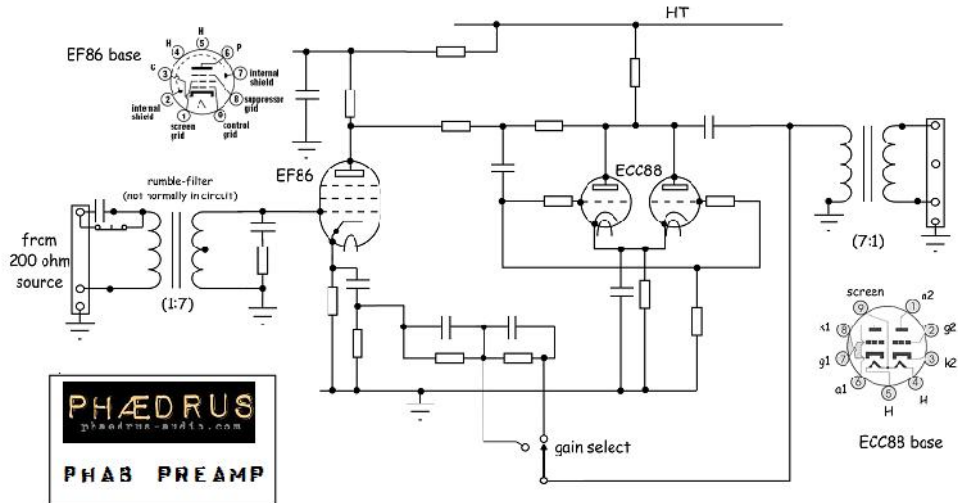

In this 1959 tube-amplifier design a EF86 pentode valve is followed by an ECC88 dual triode "strapped" as a single, high-mu tube. The PHAB-S incorporates two examples of these amplifiers; one for each channel.

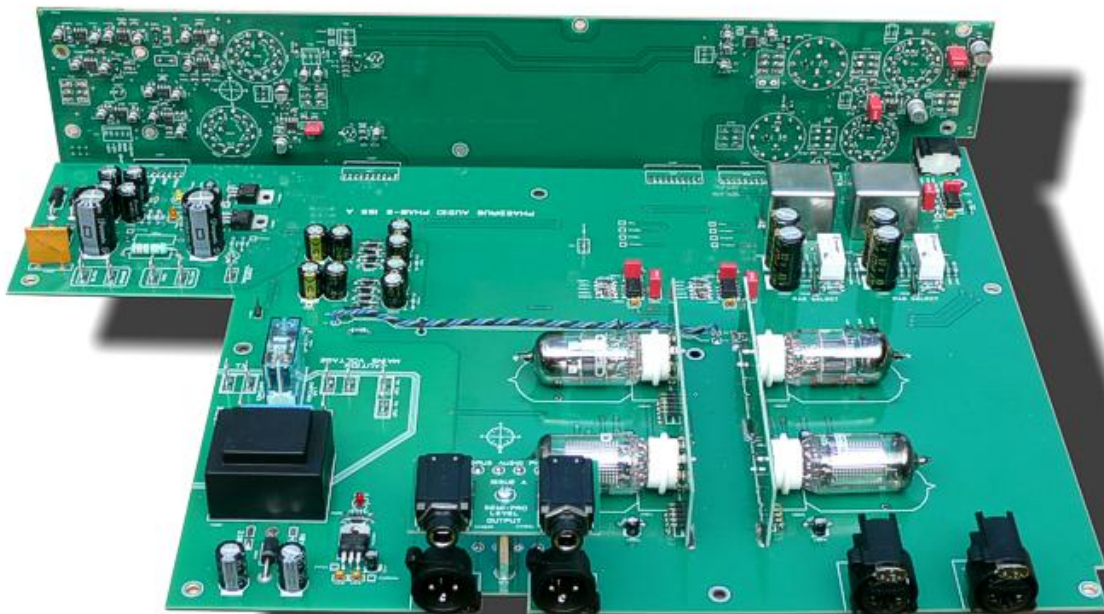

Specifications

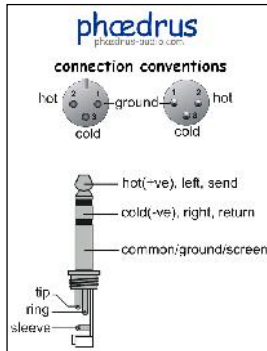

Electrical connections

Input:

Unbalanced: 3 pin XLR Connector Balanced: 3 pin XLR Connector

Pin 1 – Ground Pin 1 – Ground

Pin 2 – (+) Signal Pin 2 – (+) Signal

Pin 3 – Connect to Pin 1 Pin 3 – (-) Signal

Output:

Unbalanced: 3 pin XLR Connector Balanced: 3 pin XLR Connector

Pin 1 – Ground Pin 1 – Ground

Pin 2 – (+) Signal Pin 2 – (+) Signal

Pin 3 – Leave o/c Pin 3 – (-) Signal

PHAB-S Specification

Input: Balanced, transformer coupled

Output: Balanced on XLR, balanced/unbalanced RTS jack

Gain (maximum): 53dB

Preamp attenuator: 40dB range in 4dB steps

Pad: -20dB (30dB selectable via an internal link)

Frequency response: ± 1 dB 40Hz and 15 kHz (HPF out of circuit)

Crosstalk (L & R mode): better than -60dB at 10kHz

EIN: 400nV RMS, -126dBu; max gain, input terminated in 200R, unweighted reading (BW 300Hz – 20kHz)

Maximum output level (XLR): +24dBu @ 1kHz. Clip LED indicates RED at 3dB below clipping level

Maximum output level (Jack): +18dBu @ 1kHz un-balanced. Clip LED indicates RED at 3dB below clipping level

Power supply: 230 AC or 110V AC (specify at time of order)

Power consumption: 20 Watts

Phantom Supply: +48V DC, up to 5mA/channel

Phaedrus Audio Ltd. reserves the right to alter these specifications without notice.

Declaration of Conformity

The Manufacturer of the Products covered by this Declaration is

Phædrus Audio Ltd.
head office address

The directives covered by this declaration are:

89/336/EEC Electromagnetic Compatibility directive
73/23/EEC Low Voltage Equipment directive

The products covered by this declaration are:

Phædrus Audio PHAB-S

The basis on which conformity is being declared:

The manufacturer hereby declares that the products identified above comply with the protection requirements of the EMC directive and with the principal elements of the safety objectives of the Low Voltage Equipment directive, and that the following standards have been applied:

IEC INTERNATIONAL STANDARD 60065 - Audio, video and similar electronic apparatus – Safety requirements

The technical documentation required to demonstrate that the products meet the requirements of the Low Voltage Equipment directive has been compiled and is available for inspection by the relevant enforcement authorities. The CE mark was first applied in 2011.



Signed:

Richard Brice . Phædrus Audio

Date:

July 2017